

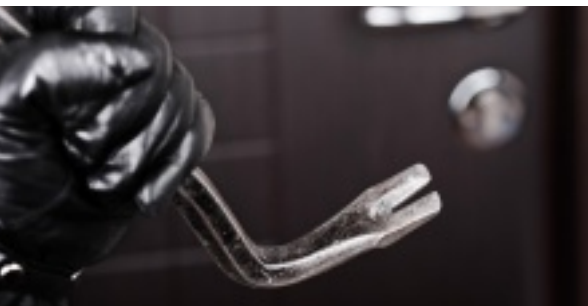

BURGLARY RESISTANT  
**COMPACT SAFE**  
DESIGNED TO PROTECT  
PISTOLS FROM THEFT



# PISTOL SAFE

BURGLARY-RESISTANT SAFE

## KEY FEATURES

- Designed to protect pistols from theft
- Supplied with a key lock
- Incorporates anti-drill protection
- Welded lock strap behind lock



# PISTOL SAFE

## PRODUCT SPECIFICATIONS

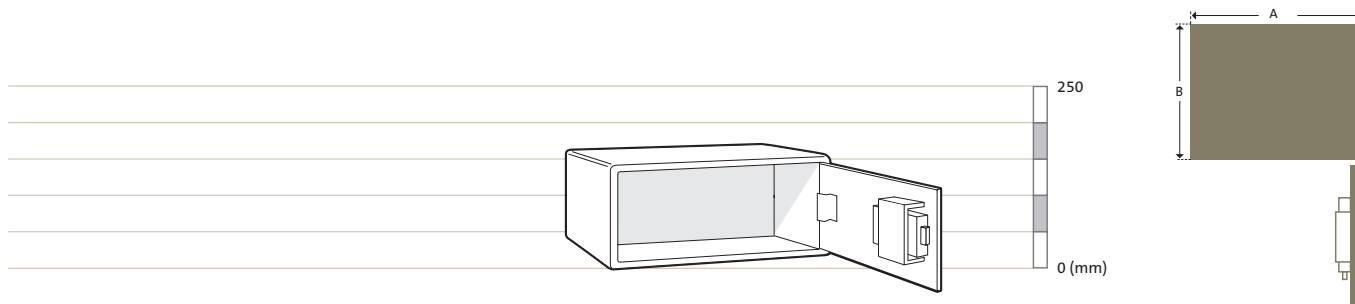

Model	External Height (mm)	External Width (mm)	External Depth (mm)	Internal Height (mm)	Internal Width (mm)	Internal Depth (mm)	Weight (kg)	Standard Internal Fittings
Pistol Safe	140	320	250	128	308	218	16	-

\* Dimensions exclude handle and hinge projections

## LOCKS



Pistol Safe comes with a manual key operated lock for extra safety and convenience to safeguard your valuables.

Toll Free Phone: 1800 450 777

[www.chubbsafes.com.au](http://www.chubbsafes.com.au)